

RESOLUTION MEPC.104(49)  
Adopted on 18 July 2003  
GUIDELINES FOR BRIEF SAMPLING OF  
ANTI-FOULING SYSTEMS ON SHIPS

**ANNEX 9**

**RESOLUTION MEPC.104(49)**

**Adopted on 18 July 2003**

**GUIDELINES FOR BRIEF SAMPLING OF ANTI-FOULING SYSTEMS ON SHIPS**

THE MARINE ENVIRONMENT PROTECTION COMMITTEE,

RECALLING Article 38(a) of the Convention on the International Maritime Organization concerning the functions of the Marine Environment Protection Committee conferred upon it by the international conventions for the prevention and control of marine pollution,

RECALLING ALSO that the International Conference on the Control of Harmful Anti-fouling Systems for Ships, 2001, held in October 2001, adopted the International Convention on the Control of Harmful Anti-fouling Systems on Ships, 2001 (the AFS Convention) together with four Conference resolutions,

NOTING that article 11(1) of the AFS Convention prescribes that ships to which this Convention applies may, in any port, shipyard, or offshore terminal of a Party, be inspected by officers authorized by that Party for the purpose of determining whether the ship is in compliance with this Convention, and that such inspection includes brief sampling of the ship's anti-fouling system,

NOTING ALSO that article 11(1) of the AFS Convention refers to the guidelines to be developed by the Organization and Conference resolution 2 urges the Organization to develop these guidelines as a matter of urgency for them to be adopted before the entry into force of the Convention,

NOTING FURTHER that through resolutions MEPC.102(48) and MEPC.105(49) the Organization has developed "Guidelines for Survey and Certification of Anti-fouling Systems on Ships" and "Guidelines for Inspection of Anti-fouling Systems on Ships", respectively, and

HAVING CONSIDERED the recommendation made by the Sub-Committee on Flag State Implementation at its eleventh session,

1. ADOPTS the Guidelines for brief sampling of anti-fouling systems on ships, the text of which is set out in the Annex to this resolution;
2. INVITES Governments to apply the Guidelines as soon as possible, or when the Convention becomes applicable to them; and
3. RECOMMENDS that the Guidelines be reviewed on a regular basis.

## ANNEX

### GUIDELINES FOR BRIEF SAMPLING OF ANTI-FOULING SYSTEMS ON SHIPS

#### TABLE OF CONTENTS

#### 1. General

Purpose  
Structure of these Guidelines

#### 2. Definitions

#### 3. Personnel safety when sampling

Health  
Safety

#### 4. Sampling and analysis

Sampling methods  
Technical aspects  
Sampling strategy and number of samples  
Analysis

#### 5. Thresholds and tolerance limits

Thresholds  
Tolerance range

#### 6. Definition of compliance

#### 7. Documentation and recording of information

**Appendix:** Possible methods for brief sampling and analysis of anti-fouling systems on ships - organotin

Method 1

Appendix to Method 1: Record sheet for the brief sampling procedure for compliance with the Convention in terms of the presence of organotin acting as a biocide in anti-fouling systems on ship hulls

Method 2

Appendix to Method 2: Record sheet for the sampling and analysis of anti-fouling systems on ship hulls - organotin compounds

## 1 General

### Purpose

1.1 Article 11 of the International Convention on the Control of Harmful Anti-fouling Systems on Ships, 2001, hereinafter referred to as “the Convention”, and resolution MEPC.102(48) Guidelines for Survey and Certification of Anti-Fouling Systems on Ships refer to sampling as a method of verification of compliance of a ships anti fouling system with the Convention for inspection and survey.

1.2 The “Guidelines for Brief Sampling of Anti-Fouling Systems on Ships”, hereinafter referred to as “the Guidelines”, provide procedures for sampling to support the effectiveness of survey and inspection to ensure that a ship’s anti-fouling system complies with the Convention and thus assists:

- .1 Administrations and recognized organizations (ROs) in the uniform application of the provisions of the Convention;
- .2 port State control officers with guidance on methods and handling of brief sampling in accordance with Article 11(1)(b) of the Convention; and
- .3 companies, shipbuilders, manufacturers of anti-fouling systems, as well as any other interested parties in understanding the process of sampling as required in terms of the Convention.

1.3 However, inspections or surveys do not necessarily always need to include sampling of anti-fouling system.

1.4 These Guidelines apply to surveys and inspections of ships subject to the Convention.

1.5 The sole purpose of the sampling activities described in the Guidelines is to verify compliance with the provisions of the Convention. Consequently, such activities do not relate to any aspect not regulated by the Convention, (even if such aspects relate to the performance of an anti-fouling system on the hull of a ship, including the quality of workmanship).

### Structure of these Guidelines

1.6 These Guidelines contain:

- .1 a main body covering aspects of general nature common to “sampling” procedures related to the regulation of anti-fouling systems controlled by the Convention; and
- .2 appendices describing the unique procedures associated with the sampling and analysis of anti-fouling systems controlled by the Convention. These appendices only serve as examples of sampling and analytical methods and other sampling methods not described in an appendix may be used subject to the satisfaction of the Administration or the port State, as appropriate.

1.7 For reasons including the event of other anti-fouling systems becoming controlled under the Convention, or in the light of new experience acquired, these Guidelines may need to be reviewed or amended in the future.

## **2 Definitions**

For the purposes of these Guidelines:

2.1 “Administration” means the Government of the State under whose authority the ship is operating. With respect to a ship entitled to fly a flag of a State, the Administration is the Government of that State. With respect to fixed or floating platforms engaged in exploration and exploitation of the sea-bed and subsoil thereof adjacent to the coast over which the coastal State exercises sovereign rights for the purposes of exploration and exploitation of their natural resources, the Administration is the Government of the coastal State concerned.

2.2 “Anti-fouling system” means a coating, paint, surface treatment, surface or device that is used on a ship in order to control or prevent attachment of unwanted organisms.

2.3 “Threshold value” means the concentration limit of the chemical under investigation below which compliance with the relevant provisions of the Convention may be assumed.

2.4 “Company” means the owner of the ship or any other organization or person such as the manager or the bareboat charterer, who has assumed the responsibility for the operation of the ship from the owner of the ship and who, on assuming such responsibility, has agreed to take over all duties and responsibilities imposed by the International Safety Management (ISM) Code.

2.5 “Length” means the length as defined in the International Convention on Load Lines, 1966, as modified by the Protocol of 1988 relating thereto, or any successor Convention.

2.6 “Tolerance range” means the numerical range added to the threshold value indicating the range where detected concentrations above the threshold value are acceptable due to recognised analytical inaccuracy and thus do not compromise the assumption of compliance.

## **3 Personnel safety when sampling**

### **Health**

3.1 Persons carrying out sampling should be aware that solvents or other materials used for sampling may be harmful. Wet paint which is sampled may also be harmful. In these cases the material safety data sheet (MSDS) for the solvent or paint should be read and appropriate precautions should be taken. This will normally include the wearing of long sleeve solvent resistant gloves of suitable impervious material - e.g. nitrile rubber.

3.2 Quantities of dry anti-fouling paint removed during sampling from ships' hulls will normally be too small to cause significant health effects.

### **Safety**

3.3 Access to ships to carry out sampling safely may be difficult. If a ship is moored alongside persons carrying out sampling must ensure they have safe access to reach the hull from e.g. platforms, crane baskets, cherry-pickers, gangways. They must ensure that they are protected by railings or a climbing harness or take other precautions so that they cannot fall into the water between the quay and the ship. If in doubt a lifejacket and possibly a safety line, should be worn when sampling.

3.4 Access to ships in dry-dock should be made by secure means. Scaffolding should be securely constructed and cherry-pickers or dock-arms should be properly constructed and maintained if they are to be used to gain access. There should be a system to record the presence of the inspector in the dock area, and he should preferably be accompanied. Safety harnesses should be worn in cherry-picker baskets, if used.

## **4 Sampling and Analysis**

### **Sampling methods**

4.1 During sampling, care should be taken not to affect the integrity or operation of the anti-fouling system.

4.2 Sampling where the anti-fouling coating is visibly damaged<sup>1</sup> or on block mark areas on the flat bottom of the ship (where the intact anti-fouling system is not applied) should be avoided. Sampling adjacent to or below areas where the anti-fouling system is damaged should also be avoided. When a sample point on the hull has been selected, any fouling present should be removed with water and a soft sponge/cloth before taking a specimen of the anti-fouling system (to avoid contamination of sample). Where possible, if carried out in dry-dock, sampling should be carried out after the hull has been water-washed.

4.3 The materials required for brief sampling methodologies should ideally be inexpensive, widely available and therefore readily accessible, irrespective of sampling conditions and/or location.

4.4 The sampling procedure should ideally be easily and reliably undertaken. Persons conducting sampling should receive appropriate training in sampling methods.

### **Technical aspects**

4.5 The sampling method should take into account the type of anti-fouling system used on the ship.

4.6 Specimens of paint for analysis during survey and certification can be taken either as wet paint<sup>2</sup> from product containers, or dry paint film sampled from the hull.

### **Sampling strategy and number of samples**

4.7 The sampling strategy is dependent on the precision of the sampling method, the analytical requirements, costs and required time and the purpose of the sampling. The number of

---

<sup>1</sup> During in-service periods, anti-fouling coatings on ships' hulls often become damaged. The extent of damage varies between ships and damaged areas can be visually recognised. Typically damage can be restricted to localised areas e.g. anchor chain damage (bow region), fender damage (vertical sides of hull), 'rust through areas' (underlying rust causing coating failure) or in some cases be in smaller areas scattered over larger areas of the hull (usually older ships where over-coating of original system has taken place many times).

<sup>2</sup> In order to prevent contamination, wet paint samples should be taken from a newly opened container. Paint should be stirred to ensure even consistency before sampling and all equipment used should be cleaned prior to use. Liquid paint samples should be stored in appropriate sealed packaging which will not react with or contaminate the sample. In the case of multi-component coatings (where on-site mixing of several components is required prior to application), samples of each component should be taken and the required mixing ratio recorded. When a sample of wet paint is taken from a container, details of the paint should be recorded e.g. details required for the IAFS Certificate along with a batch number for the product.

paint specimens taken of each sample should allow for a retention quantity for back-up/storage in the event of a dispute. For dry samples, triplicate specimens of paint at each sampling point should be taken in close proximity to each other on the hull (e.g. within 10 cm of each other).

4.8 In cases where it is recognized that more than one type of anti-fouling system is present on the hull, where access can be gained, samples should be taken from each type of system:

- .1 for survey purposes or for more thorough inspections pursuant to article 11(2) of the Convention, in order to verify the compliance of an anti-fouling system, the number of sample points should reflect representative areas of the ship's hull; and
- .2 for inspection purposes pursuant to article 11(1) of the Convention sample points on the hull should be selected covering representative areas where the anti-fouling system is intact. Depending on the size of the vessel and accessibility to the hull, at least four sample points should be equally spaced down the length of the hull. If sampling is undertaken in dry-dock, flat bottom areas of the hull should be sampled in addition to vertical sides as different anti-fouling systems can be present on these different areas.

### **Analysis**

4.9 The analysis of the anti-fouling system should ideally involve minimal analytical effort and economic cost.

4.10 The analysis should be conducted by a recognized laboratory meeting the ISO 17025 standard or another appropriate facility at the discretion of the Administration or the port State.

4.11 The analytical process should be expeditious, such that results are rapidly communicated to the officers authorized to enforce the Convention.

4.12 The analysis should produce unambiguous results expressed in units consistent with the Convention and its associated Guidelines. For example, for organotin, results should be expressed as: mg tin (Sn) per kg of dry paint.

NOTE: Compound-specific sampling and analytical methodologies are described in the appendices to these Guidelines.

## **5 Thresholds and tolerance limits**

### **Thresholds**

5.1 The analysis should be quantitative to the point of being able to accurately verify the threshold limits within the given tolerance.

5.2 In cases where compliance with acceptable limits, or lack thereof, is unclear, additional sampling or other methodologies for sampling should be considered.

### **Tolerance range**

5.3 Statistical reliability for each (compound-specific) brief sampling procedure should be documented. The analysis should be quantitative to the point of being able to accurately verify

the threshold limits within the given tolerance. On the basis of these data a compound-specific tolerance range should be derived and stated compound-specific in the method description. In general, the tolerance range should not be higher than the standard deviation under typical conditions for testing and should under no circumstances go beyond 30 %.

## **6 Definition of compliance**

6.1 Compliance with Annex 1 of the Convention is assumed if the anti-fouling system contains organotin at a level which does not provide a biocidal effect. In practice organotin compounds should not be present above 2,500 mg organotin (measured as Sn) per kg of dry paint.

6.2 Compliance is largely dependent on the results of sampling and subsequent analysis. As every method of sampling and analysis has its specific accuracy, a compound-specific tolerance level may be applied in borderline cases with concentrations very close to the threshold level.

6.3 In general, compliance is assumed when the samples yield results below the threshold value.

## **7 Documentation and recording of information**

7.1 The results of the sampling procedure should be fully documented on a method-specific record sheet. Examples are provided in the appendices to these Guidelines.

7.2 Such record sheets should be completed by the sampler and should be submitted to the competent authority of the Port State or Administration.

## APPENDIX

### POSSIBLE METHODS FOR BRIEF SAMPLING AND ANALYSIS OF ANTI-FOULING SYSTEMS ON SHIPS

#### - ORGANOTIN -

#### METHOD 1

#### 1 Purpose of this method concerning brief sampling and analysis of anti-fouling systems

1.1 This method has been developed in order to describe a rapid methodology appropriate for the identification of anti-fouling systems on ship hulls containing organotin compounds acting as biocide. This method has been designed such that sealers should not be affected, and any underlying anti-fouling agent (or primer) is not taken up in the sampling procedure. The method is not recommended for silicon-based anti-fouling systems.

1.2 This method is based on a two-step analysis. The first step detects total tin as an indicator for organotin; the second step, detecting specific organotin compounds, is only necessary in the case of the first step proving positive.

#### 2 Sampling device and materials

2.1 The sampling device is constructed in a way that only the upper layer of paint is removed, thereby and should leave any underlying paint (sealer, primer etc.) intact. This result is achieved through the use of a moving disk, (eccentric rotation) which is covered by an abrasive material like quartz or glass fibre fabric. This abrasive material has to be suitable for its use as a supporting material for the removed paint.

2.2 The device fulfils the following requirements:

- .1 the device has to work independently from any stationary power supply. The device may be driven by an electrical motor (battery-driven) or may be mechanically driven by a clockwork-like spring, provided it is able to sustain the movement over the required time period;
- .2 the applied force has to be constant during the operation, and the area for paint removal has to be defined;
- .3 the abrasive material has to be inert against chemical solvents and acids and must not contain more than trace amounts of tin or tin compounds; and
- .4 the amount of paint removed after a regular operation of the device has to be shown to exceed 20 mg per sample.

2.3 The device as described in the following section has been shown to be suitable for the brief sampling procedure. Any other device may be used however, provided such a device has proven to meet all the above-mentioned requirements.

2.4 The sampling device described here consists of a polyethylene disk, on which fibre glass fabric can be mounted by the use of an O-ring. The disk is moved on an eccentrically rotating axis.

### **3 Sampling procedure**

3.1 The sampling procedure should be performed in the following manner:

- .1 control samples should be taken through the entire sampling and analytical process to account for possible contamination;
- .2 the mass of the fibre glass pads is weighed with a precision of at least 1 mg. The weight should be documented for each sample;
- .3 the fabric should be moistened thoroughly with isopropanol (0.7ml per sample) immediately before sampling;
- .4 when a sample point on the hull has been selected, any fouling present should be removed with water and a soft sponge/cloth before taking a specimen of the anti-fouling system (to avoid contamination of sample). Where possible, if carried out in dry-dock, sampling should be carried out after the hull has been water-washed;
- .5 the sampling device is then held against the surface to be sampled for a period of 5 seconds, prior to the sampling device being switched on;
- .6 the sampling device is switched on, thereby removing paint by the circular motion of the fibre glass fabric against the surface of the ship;
- .7 the sampling device should be applied to the surface of the hull for a suitable period of time, such that at least 20 mg of paint is taken up by the pad. As a general rule, if the pad colour after sampling matches the colour of the hull coating a sufficient sample has been taken;
- .8 the two-step analysis procedure requires that every sample should be taken in triplicate. Two of the specimens should be labelled Specimen 'A' and Specimen 'B'. In addition a third specimen for storage/back-up should be taken. These specimens should be taken as close to each other as possible, but without overlap; and
- .9 upon completion of the sampling, the fibre glass fabric pads should be left to dry, and re-weighed.

3.2 Samples should be stored in appropriate sealed packaging, which will not react with or contaminate the sample.

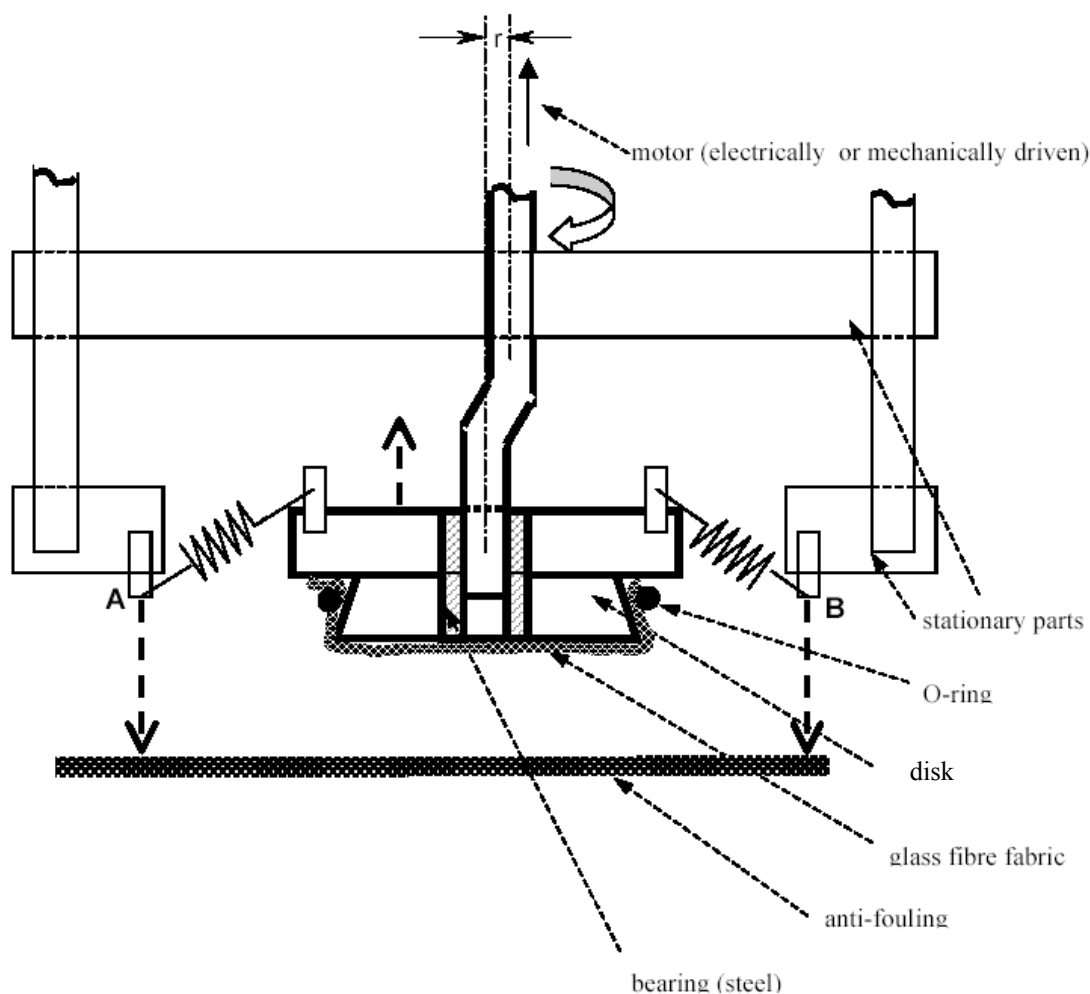

**DIAGRAM A: Schematic cross section of the sampling device**

The indicated points A and B are to be pressed against the surface. The polyethylene disk, covered with the glass fibre fabric, is moved with an amplitude of  $2r$  ( $r = 1,0$  cm) on the surface.

**Specific data:**

Force applied on the paint surface:	25N (Newton)
Effective diameter of the disk:	5cm
Frequency of rotation:	6 rotations/s
Solvent used	isopropanol (0.8ml per sample).

**4 Sampling strategy**

4.1 Sampling should be conducted in accordance with paragraph 4 of the Guidelines.

4.2 For inspection purposes in most cases accessibility to all parts of the hull will not be given. A minimum number of eight independent samples should be taken from different accessible parts of the hull.

## **5 Analytical procedure**

5.1 The two components comprising the analytical procedure are illustrated in the flow diagram B. The two components, or steps, are as follows:

- .1 (STEP 1) - An analysis of Specimen A for the presence of total tin; and
- .2 (STEP 2) - A more cost- and time-consuming analysis of Specimen B, that is applied only when Step 1 produces positive results. This test involves organotin analysis by gas chromatography/mass spectrophotometry (GC/MS) after derivatisation and provides specific data on the respective organotin species.

### **Step 1: Investigation of total tin content in Specimen 'A'**

#### **Analysis of Specimen 'A'**

5.2 Specimen 'A' is analysed for mass of total tin per kilogram of dry paint (or mass of tin per sample) by applying inductively coupled plasma/mass spectrometry (ICP/MS), once the material had been solubilized by digestion using aqua regia. It should be noted that any other scientifically recognized procedure for tin analysis (such as AAS, XRF and ICP-OES) is acceptable.

### **Step 2: Characterization of organotin in Specimen 'B'**

#### **Analysis of Specimen 'B'**

5.3 Should Specimen 'A' produce positive results, organotin compounds should be identified and quantified in Specimen 'B'. Specimen 'B' may be analysed using the following procedure:

- .1 solvent extraction of Specimen 'B' as supported by sonication in an ultrasonic bath;
- .2 derivatisation with ethylmagnesium bromide;
- .3 clean-up of the extract;
- .4 analysis using high resolution gas chromatography/mass spectrophotometry (GC/MS); and
- .5 quantifications using tripropyltin as a standard.

5.5 Any equally reliable method for the chemical identification and quantification of organotin compounds is acceptable.

## **6 Threshold and tolerance range**

6.1 The threshold value for the brief sampling method as described here is:

"2,500mg tin (Sn) per kg of dry paint."

## Tolerance range

6.2 The tolerance range is 500mg Sn / kg of dry paint (20%) in addition to the threshold value.

## Organotin containing compounds acting as biocides or catalysts

6.3 As stated in the appendix of resolution MEPC.102(48), for the purposes of defining compliance with annex 1 of the Convention, it should be noted that small quantities of organotin compounds, acting as chemical catalysts (such as mono- and di-substituted organotin compounds) are allowed, provided they are not acting as a biocide.

6.4 Inorganic impurities in the constituents of the paints should be considered.

6.5 At present neither organotin catalysts nor inorganic impurities are found at concentrations which will be close to the threshold level (2,500mg Sn/kg of dry paint) or higher. However, organotin-containing compounds, when present in paint in order to act as a biocide, were found in concentrations up to 50,000mg Sn/kg of dry paint. Thus the discrimination between anti-fouling systems containing organotin compounds acting as a biocide and anti-fouling systems not containing these compounds or not containing these compounds at concentrations where they act as a biocide, is reliably possible.

## 7 Definition of compliance

### Two-step procedure

7.1 The analytical verification of the compliance with the Convention is performed in a two-step procedure according to the flow-diagram (diagram B).

Step 1:

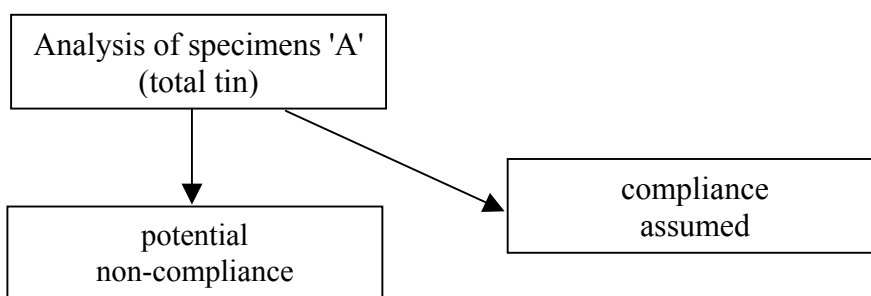

Step 2:

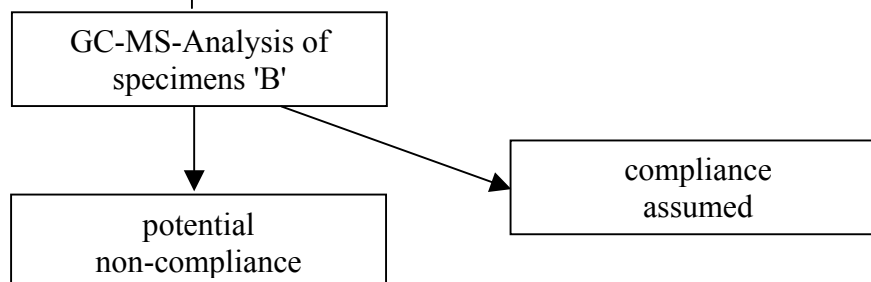

**DIAGRAM B: Flow diagram illustrating the two-step analysis procedure**

### **Compliance with the criteria at the 'Step 1-level'**

7.2 Compliance with the Convention is assumed when the results from the specimens 'A', analysed in step 1, meet the following:

- .1 no more than 25% of the total number of samples yield results above 2,500 milligrams total tin per kilogram dry paint (2,500 mg Sn/kg of dry paint); and
- .2 no sample of the total number of at least eight samples shows a concentration of total tin higher than the sum of threshold value plus the tolerance range, i.e. no sample must exceed the concentration 3,000 mg Sn/kg of dry paint.

7.3 If the results in specimen 'A' indicate that no organotin acting as biocide is present, then performing step 2 is not necessary.

### **Non-compliance with the criteria at the 'Step 1-level'**

7.4 A positive result (non-compliance) is indicated if provisions of paragraph 7.2 are not met.

7.5 A positive result at step 1 (specimen 'A') would indicate that step 2 should be undertaken, and those samples labelled specimen 'B' should be analysed in order to determine and characterize the organotin present (see diagram B).

### **Compliance with the criteria at the 'Step 2-level'**

7.6 Compliance with the Convention is assumed when the results from the specimens 'B', analysed in step 2, meet the following requirements at the same time:

- .1 no more than 25% of the total number of samples yield results above 2,500 milligrams total tin per kilogram dry paint (2,500 mg Sn/kg of dry paint); and
- .2 no sample of the total number of at least eight samples shows a concentration of total tin higher than the sum of threshold value plus the tolerance range, i.e., no sample must exceed the concentration 3,000 mg Sn/kg of dry paint.

### **Non-compliance at 'step 2-level'**

7.7 A positive result in step 2 indicates non-compliance if the provisions of paragraph 7.6 are not met. Such results should be interpreted to mean that organotin compounds are present in the anti-fouling system at a level at which it would act as a biocide.

**APPENDIX TO METHOD 1**

**RECORD SHEET FOR THE BRIEF SAMPLING PROCEDURE FOR COMPLIANCE  
WITH THE CONVENTION IN TERMS OF THE PRESENCE OF ORGANOTIN  
ACTING AS A BIOCIDES IN ANTI-FOULING SYSTEMS ON SHIP HULLS**

<b>RECORD SHEET :</b>		<b>RECORD NUMBER:</b>
<b>GUIDELINES FOR BRIEF SAMPLING OF ANTI-FOULING SYSTEMS ON SHIPS - ORGANOTIN -</b>		
<b><u>SECTION A: Administration</u></b>		
<b>1. Country</b>	<b>2. Name of port</b>	<b>3. Date</b>
<b>4. Reason for sampling:</b>		
<input type="checkbox"/> Port State control <input type="checkbox"/> Survey & Certification <input type="checkbox"/> Other flag State compliance inspection		
<b>5. Company details:</b>		<b>6. Inspecting official's details</b>
1. Name of ship: 2. Distinctive number or letters: 3. Port of registry: 4. Gross tonnage: 5. IMO number:		1. Name: 2. Comments:
<b><u>SECTION B: Sampling</u></b>		
1. Time sampling procedure initiated:		
2. Description of location from where samples were taken (frame number and distance from boot topping, refer to paragraph 3.2):		
3. Number of samples taken (three specimens per sample):		
4. Photographs taken of the sample points prior to sampling? <input type="checkbox"/> Yes <input type="checkbox"/> No		
5. Time sampling procedure completed:		
6. Additional comments concerning sampling procedure:		



7. Summarized conclusion:	
Compliance assumed	<input type="checkbox"/>
Non-compliance assumed	<input type="checkbox"/>
<b>THIS IS TO CERTIFY that this Record is correct in all respects.</b>	
Issued at .....	
(Place of issue of Record)	
.....	.....
(Date of issue)	(Printed name and signature of authorized official issuing the Record)
(Seal or stamp of the authority /organization)	

## METHOD 2

### 1 Purpose of this method

1.1 This method provides sampling and analysis procedures to identify the presence of organotin compounds in the anti-fouling systems on ships. The method is designed such that the sampling and the first stage analysis could be carried out by ship surveyors or port State control officers (PSCOs) on the survey/inspection site, e.g. at a dry dock.

1.2 This method is based on a two-stage analysis. The first stage detects total tin as an indicator for the presence of organotin and the second stage is necessary only in the case that the first stage analysis providing a positive result to detect specific organotin compounds.

### 2 Sampling

2.1 The sampling is carried out by using abrasive paper rubbing on the surface of the anti-fouling system. This results in collection of paint fragment of the anti-fouling system from thin area, less than several micrometer in depth from the surface, which do not affect the coatings lying underneath such as sealers.

2.2 Abrasive paper is pasted on a disc of approximately 10 mm in diameter. Rubbing the surface of the anti-fouling system with the disc collects several milligrams of the sample on to the abrasive paper.

2.3 The sampling device consists of an electric motor, two (or three) rotating rods on each of which a disc is attached, and a battery for electric power supply. The discs are pressed on to the surface of ship's hull by spring coils. The disks rotate counter-clockwise while the rods turn clockwise around the centre of the device. Schematic diagram is illustrated in figure 1.

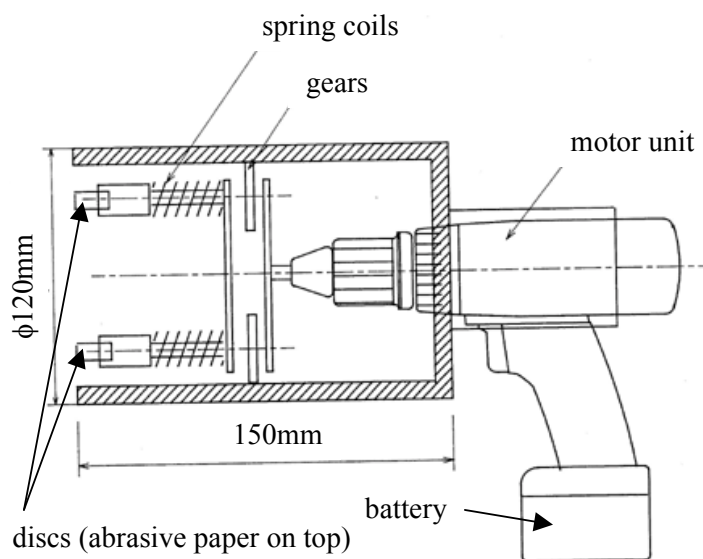

Figure 1. Schematic diagram of sampling device

2.4 Sampling point is selected such that the anti-fouling system is intact over an area of approximately 50 cm x 50 cm or more. At each sampling point, three sets of sampling, or more if necessary, should be carried out to obtain at least six specimens.

2.5 The device is pressed on the ship's hull where it is appropriate to be sampled and held by hand. The electric motor is switched on to slide along the painted surface to lightly scrape off the fragments of the paint onto the abrasive paper. After the sample collection, each disc is removed from the device and stored in an inert container.

2.6 Sampling should normally be carried out with the sampling device. However, in the case that accessibility to the sampling point is poor, it is acceptable to collect samples with the discs by hand if necessary.

### **3 The first-stage analysis**

3.1 The first-stage analysis is assumed to be carried out on the spot of the survey or inspection, e.g. dry docks and sea ports. In order to accomplish the on-site analysis, X-ray fluorescence analysis (XRF) is used in this method to detect total tin content.

3.2 Analytical characteristics, such as detection limit and accuracy, are highly dependent on the type of the instrument, i.e. type of X-ray tube, spectrometer, optical arrangement (filters or collimators), etc. Among several types of the XRF instruments, an energy-dispersive spectrometer with a silicon drift detector (SDD), which is compact in size and be able to be operated without liquid nitrogen, is preferable to the present analytical system for a field use, whereas wave-length dispersion system or solid-state detector are also available if the analysis carried out at laboratories.

3.3 Software customized for the tin analysis is prepared to assist the operator, who is assumed to be a ship surveyor or PSCO, to detect total tin in the specimens.

3.4 The customized software may in advance need a calibration curve of the characteristic X-ray intensity of tin in relation to the tin content particularly in the range of 0.1 to 0.5%.

3.5 After the preparation including the warming-up of the XRF instrument and starting-up of the computer, a specimen (sampling disc) is placed on the sample stage of the instrument. Afterwards, analysis is executed by the customized software. A single batch of analysis for one specimen normally takes 5 minutes and the result is shown on a display automatically.

3.6 Since the XRF analysis does not affect any properties of the specimens, all of the collected specimens (six to nine specimens), including those for the second analysis and storage, are able to be used for this analysis.

### **4 Interpretation of the result at the first-stage analysis**

4.1 Following the procedures above, XRF data of six, or nine, specimens are obtained for each sampling point. Omitting the maximum and minimum values from the data, an average of the tin content is calculated from the intermediate values for the representing value of the sampling point.

4.2 Compliance with the Convention is assumed when none of the tin contents (average values) from the samples do not exceed the sum of the threshold (2,500 mg per kg) and a tolerance (500 mg per kg).

4.3 When one or more average values of samples from different sampling points do not meet the above criteria, the samples should be sent to a laboratory for the second stage analysis. Regardless of the results, it is also possible to undergo the second stage analysis when the surveyor or PSCO considers that it is necessary to do so.

## **5 Second-stage analysis**

5.1 Since the second-stage analysis provides the final and definitive results of the samples, the method should be thoroughly reviewed by experts based on scientific evidence. The following is a brief summary of a tentative methodology for the second stage analysis.

5.2 The collected paint specimens are removed from the abrasive paper and total mass is measured with an electronic balance to an order of 0.1 mg. The specimens are hydrolysed with sodium hydroxide aqueous solution, extracted with organic solvent, and then derivatised with propylmagnesium bromide. After cleaning up the extract, analysis using high resolution gas chromatography/mass spectrometry (GC/MS) is carried out. For quantification analysis, tetrabutyl tin d36 is added as the internal standard.

5.3 These analyses provide the data of chemical species and their content (mg per kg of the specimens). The content of organotin is obtained in a unit of mg per kg of dry paint.

## **6 Compliance with the Convention**

6.1 Compliance with the Convention is assumed when the results from the second-stage analysis meet the following requirements at the same time:

- .1 no more than 25% of the total number of samples yield results above 2,500 milligrams tin as organic form per kilogram dry paint (2,500 mg Sn/kg of dry paint); and
- .2 no sample of the total number of specimens shows a concentration of tin as organic form higher than the sum of the threshold value plus the tolerance range, i.e., no sample must exceed the concentration 3,000 mg Sn/kg dry paint.

6.2 When the result does not meet the above criteria, it is interpreted to mean that organotin compounds are present in the anti-fouling system at a level where they would act as a biocide.

**APPENDIX TO METHOD 2**

**Record Sheet for the Sampling and Analysis of Anti-Fouling Systems  
 on Ship Hulls - Organotin Compounds**

Record Number	
<b>Section A: Administration</b>	
1. Country	2. Location
3. Date	
4. Reason for Survey/Inspection	
<b>5. Details of the Ship</b>	
5.1 Name of Ship	
5.2 Distinctive Number or Letters	
5.3 Gross Tonnage	5.4 Year of Built
5.5 Owner or Operator of Ship	
5.6 Flag State	5.7 Class of Ship
5.8 Authority of AFS Certificate	
5.9 Date of Issue	
5.10 Date of Last Endorsement	
5.11 IMO Number	
5.12 Name of Shipmaster	
5.13 Product Name of Anti-Fouling System	
5.14 Name of Manufacturer	
5.15 Name of Shipyard where applied	
5.16 Comments	
<b>6. Inspecting Official's Details</b>	
6.1 Name	
6.2 Comments	

	Record Number
<b>Section B: Sampling and Stage I Analysis (X-ray Fluorescence Analysis)</b>	
Date	Instrument I.D.

Sample/Location	Specimen I.D.	Sampling Disc	Content of Tin (mg/kg)		Average
			max	min	
<b>A</b>	A1	<input type="checkbox"/> abrasives		<input type="checkbox"/>	Average _____ mg/kg <input type="checkbox"/> >2,500mg/kg <input type="checkbox"/> >3,000mg/kg
	A2	<input type="checkbox"/> metal		<input type="checkbox"/>	
	A3	<input type="checkbox"/> others		<input type="checkbox"/>	
	A4	<input type="checkbox"/> abrasives		<input type="checkbox"/>	
	A5	<input type="checkbox"/> metal		<input type="checkbox"/>	
	A6	<input type="checkbox"/> others		<input type="checkbox"/>	
	A7	<input type="checkbox"/> abrasives		<input type="checkbox"/>	
	A8	<input type="checkbox"/> metal		<input type="checkbox"/>	
	A9	<input type="checkbox"/> others		<input type="checkbox"/>	
<b>B</b>	B1	<input type="checkbox"/> abrasives		<input type="checkbox"/>	Average _____ mg/kg <input type="checkbox"/> >2,500mg/kg <input type="checkbox"/> >3,000mg/kg
	B2	<input type="checkbox"/> metal		<input type="checkbox"/>	
	B3	<input type="checkbox"/> others		<input type="checkbox"/>	
	B4	<input type="checkbox"/> abrasives		<input type="checkbox"/>	
	B5	<input type="checkbox"/> metal		<input type="checkbox"/>	
	B6	<input type="checkbox"/> others		<input type="checkbox"/>	
	B7	<input type="checkbox"/> abrasives		<input type="checkbox"/>	
	B8	<input type="checkbox"/> metal		<input type="checkbox"/>	
	B9	<input type="checkbox"/> others		<input type="checkbox"/>	
<b>C</b>	C1	<input type="checkbox"/> abrasives		<input type="checkbox"/>	Average _____ mg/kg <input type="checkbox"/> >2,500mg/kg <input type="checkbox"/> >3,000mg/kg
	C2	<input type="checkbox"/> metal		<input type="checkbox"/>	
	C3	<input type="checkbox"/> others		<input type="checkbox"/>	
	C4	<input type="checkbox"/> abrasives		<input type="checkbox"/>	
	C5	<input type="checkbox"/> metal		<input type="checkbox"/>	
	C6	<input type="checkbox"/> others		<input type="checkbox"/>	
	C7	<input type="checkbox"/> abrasives		<input type="checkbox"/>	
	C8	<input type="checkbox"/> metal		<input type="checkbox"/>	
	C9	<input type="checkbox"/> others		<input type="checkbox"/>	
<b>D</b>	D1	<input type="checkbox"/> abrasives		<input type="checkbox"/>	Average _____ mg/kg <input type="checkbox"/> >2,500mg/kg <input type="checkbox"/> >3,000mg/kg
	D2	<input type="checkbox"/> metal		<input type="checkbox"/>	
	D3	<input type="checkbox"/> others		<input type="checkbox"/>	
	D4	<input type="checkbox"/> abrasives		<input type="checkbox"/>	
	D5	<input type="checkbox"/> metal		<input type="checkbox"/>	
	D6	<input type="checkbox"/> others		<input type="checkbox"/>	
	D7	<input type="checkbox"/> abrasives		<input type="checkbox"/>	
	D8	<input type="checkbox"/> metal		<input type="checkbox"/>	
	D9	<input type="checkbox"/> others		<input type="checkbox"/>	

<input type="checkbox"/> Stage II required	<input type="checkbox"/> ___ samples out of ___ are above 2,500mg/kg <input type="checkbox"/> Sample ___ is above 3,000mg/kg	<input type="checkbox"/> Compliant
Sampled by	Analyzed by	
Signature	Signature	



RESOLUTION MEPC.104(49)  
Adopted on 18 July 2003  
GUIDELINES FOR BRIEF SAMPLING OF  
ANTI-FOULING SYSTEMS ON SHIPS